



Make It Yours.

MASTERFRAME 700
MCF-MF700-KGNN-S00

BUILD. UNPARALLELED.



FEATURES

Premium Variable Friction Hinges – Heavy duty hinges hold the side wings to the mid-frame and allow for smooth repositioning at any angle depending on the user's needs. Allen keys are included to adjust the tension of the hinges to make it easier to move or allow the side wings to hold heavier parts. This level of flexibility is a key factor for users creating extremely unique water-cooling loops and setups.

Open Air Design – The open-air nature of the design provides unrestricted access to fresh air to all components in the system. The optional fan mounts allow to further guide the airflow path to a specific intake/exhaust direction, thus preventing performance-robbing heat recirculation.

Un-matched Hardware Support – For its size, MasterFrame 700 sports an unmatched level of hardware compatibility. It is designed to fit any component available, even oversized ones. Users can mount up to SSI-EEB motherboards, multiple power supplies and multiple radiators at the same time and still have room for triple slots GPUs and storage.

Extreme Water-Cooling Support – Designed with water-cooling in mind, MasterFrame 700 provides a flexible pump and reservoir mounting location and support for multiple triple-fan radiators.

Test Bench Mode – Thanks to its modular design, MasterFrame 700 can lay down horizontally and transform into an ultra-featured premium Test Bench. Cooling and power components are installed out of the way of the motherboard area for interference-free installation of components.

Panoramic Tempered Glass – The oversized panoramic tempered glass offers a greater viewing angle on the components of the system and, together with hardware-centric design of MasterFrame 700, it is the perfect way to showcase high-end components and custom cooling solutions.

VESA Mount Compatible – The MasterFrame 700 features 100mm x 100mm VESA mount compatibility, allowing it to be wall-mounted. Perfect to showcase custom loops and high-end components. *It is highly recommended to only wall mount full systems below 14Kg in total and check VESA weight standards.*

Designed For Customization – The MasterFrame 700 is designed with customization in mind. The 3-parts frame can be easily disassembled easily for painting, wrapping and other modifications.

In A Class By Itself

The MasterFrame 700 is a highly customizable open-air frame that can convert between a showcase PC chassis or a highly flexible test bench. MasterFrame 700 features a 3-part design consisting of two side wings and a fully featured motherboard tray. Four specially-designed friction hinges hold the side wings to the motherboard tray, allowing both full range of motion during assembly and stability when built, perfect for custom water-cooling loops.

In open-air frame mode, the MasterFrame 700 stands vertically to best display the components behind its panoramic tempered glass screen. The chassis offers an unmatched level of hardware compatibility, allowing for easy-fitting of oversized components.

In test bench mode, the side wings can fold down towards the CPU socket and GPU areas to allow to localize the airflow to the components, especially useful when overclocking. The wings also serve as spots to hold triple-fan radiators and other accessories, and thanks to their full range of mobility, swapping components while keeping the cooling solution in place is now easier than ever.

MasterFrame 700 can be easily customized due to its teardown-friendly design. Every component can be disassembled for custom paint jobs and modifications.

SPECIFICATIONS & PACKING INFORMATION

Product Name		MasterFrame 700
Product Number		MCF-MF700-KGNN-S00
Available Color		Black
Materials	Body	Steel
	Front Panel	Tempered Glass
	Top Panel	/
	Left Side Panel	Perforated Steel
	Right Side Panel	Perforated Steel
Dimensions (L x W x H)	Incl. Panels	702x306x410mm/ 27.64x12.05x16.14inch
Motherboard Support		All, Up to SSI-EEB
Expansion Slots		8
Drive Bays	5.25"	N/A
	Combo 3.5" / 2.5"	Up to 4 (PSU cover)
	2.5" SSD	Up to 7 (3 SSD bracket + 4 PSU cover)
I/O Panel	Power-LED Color	White
	HDD-LED Color	N/A
	USB-Ports	2x USB3.2 Gen1 Type A 1x USB3.2 Gen2 Type C
	Audio In / Out	1x 3.5mm Headset Jack (Audio+Mic)
	Reset Switch	N/A
	Other	N/A
ARGB Control		N/A
Pre-installed Fan(s)	Top	N/A
	Front	N/A
	Rear	N/A
	Bottom	N/A
Fan Support	Top	N/A
	Front	N/A
	Right side	120mm x3 / 140mm x2
	Left Side	120mm x3 / 140mm x2
Radiator Support	Top	Up to 360/420mm
	Front	N/A
	Right side	Up to 280/360mm
Clearances	Left Side	Up to 280/360mm
	CPU Cooler	158mm/6.22 inch(Open air)
	PSU(s)	210mm / 8.26 inch
Cable Routing	GPU	- Up to 450mm/17.71 inch - 310mm/12.20inch recommended for maximum compatibility
	Behind Motherboard Tray	100mm
Dust Filters		N/A
Power Supply Support		ATX x2

EAN code	4719512115152
UPC code	884102087462
Net weight	12.15 kg
Gross weight	15.24 kg
Carton dimension (L x W x H)	770x458x163mm

Cont.	W/ Pallet	Carton/ Pallet	W/O Pallet
20'	288	24	532
40'	576	26	1050
40 HQ	624	26	1200



Make It Yours.

MASTERFRAME 700

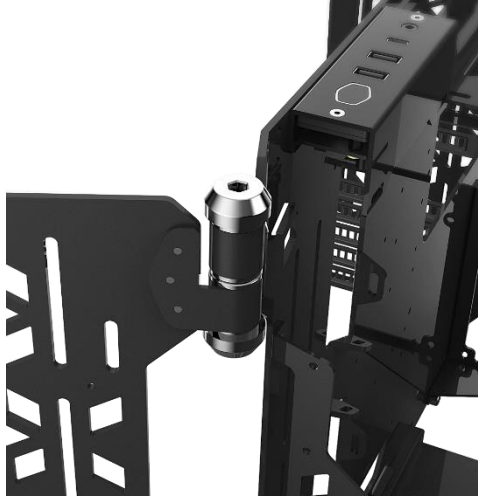

Premium Variable Friction Hinges

Heavy duty hinges hold the side wings to the mid-frame and allow for smooth repositioning at any angle depending on the user's needs. Allen keys are included to adjust the tension of the hinges to make it easier to move or allow the side wings to hold heavier parts. This level of flexibility is a key factor for users creating extremely unique water-cooling loops and setups.



Open Air Design

The open-air nature of the design provides unrestricted access to fresh air to all components in the system. The optional fan mounts allow to further guide the airflow path to a specific intake/exhaust direction, thus preventing performance-robbing heat recirculation.

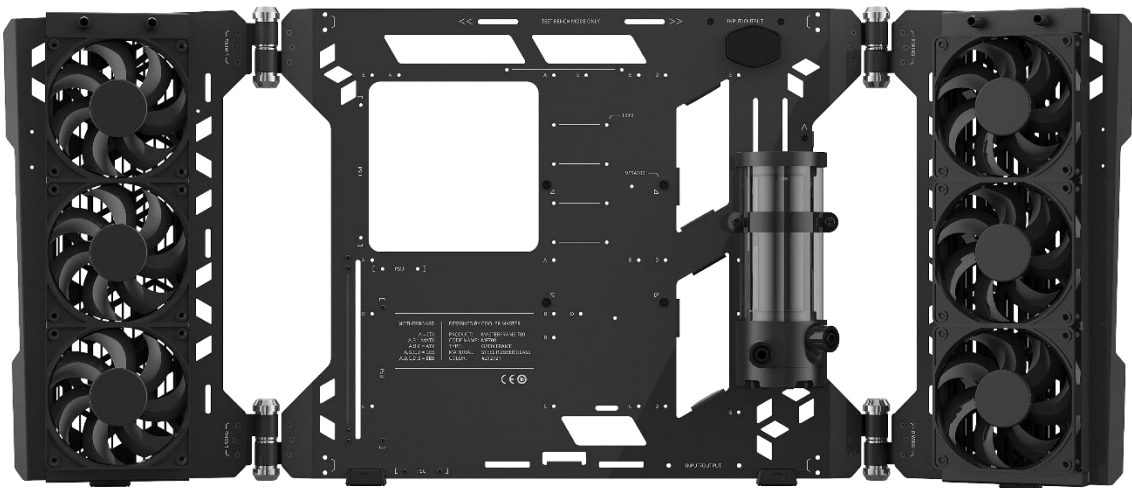

Extreme Water-Cooling Support

Designed with water-cooling in mind, MasterFrame 700 provides a flexible pump and reservoir mounting location and support for multiple triple-fan radiators.

MASTERFRAME 700

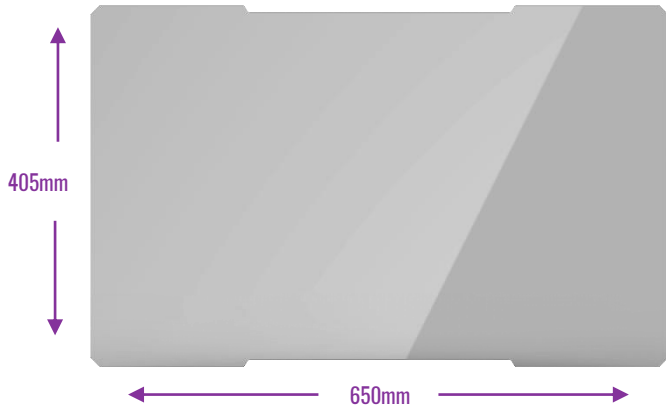

Panoramic Tempered Glass

The oversized panoramic tempered glass offers a greater viewing angle on the components of the system and, together with hardware-centric design of MasterFrame 700, it is the perfect way to showcase high-end components and custom cooling solutions.

VESA Mount Compatible

The MasterFrame 700 features 100mm x 100mm VESA mount compatibility, allowing it to be wall-mounted. Perfect to showcase custom loops and high-end components. *It is highly recommended to only wall mount full systems below 14Kg in total and check VESA weight standards.*

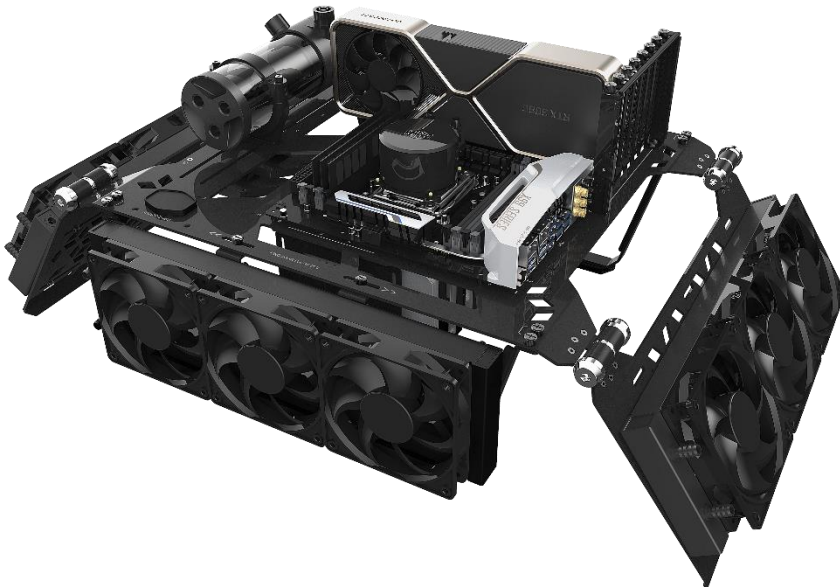

Test Bench Mode

Thanks to its modular design, MasterFrame 700 can lay down horizontally and transform into an ultra-featured premium Test Bench. Cooling and power components are installed out of the way of the motherboard area for interference-free installation of components.